

# PACK LEADER

## PL-501 WRAP AROUND LABELER

### Stepper Driven

Straightforward, clean and rugged design engineering is evident in the popular PL-501 wrap labeling system.

The real beauty shows up in the performance results of your labeled product.



Easy is the best way to describe the fast production set-up. The touch screen control allows for pre-programmed results for a wide variety of bottle sizes. This flexible capability increases your up-time and output.

**Exclusive Distributor in Canada:**  
**Speedway Packaging Machinery Inc.**  
[www.spmi.ca](http://www.spmi.ca)

# PL-501

## WRAP AROUND LABELER

### Specifications

Voltage	110 VAC 50/60 HZ 1 PHASE
Power	10 amps
Controls	Netcon touch screen
Max. Conveyor Speed	20 m (65') / min.
Max. Dispensing Speed	40 m (130') / min.
Applicator Height	150 mm (5 7/8")/200 (7 7/8") mm
Max. Label Length	350 mm (14") - Standard 500 mm (20") - Optional
Conveyor Width	100 mm (4") - Standard 150 mm (6") - Optional
Label Reel Inner	76 mm (3")
Optional	Allen hot foil coder Allen thermal transfer coder Label bar code validation

### Material

Stainless steel and anodized aluminum construction

### Dimensions

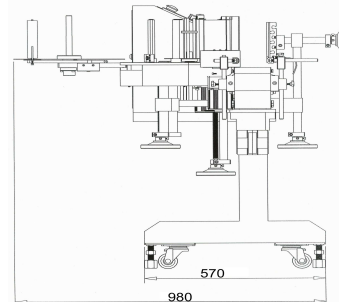
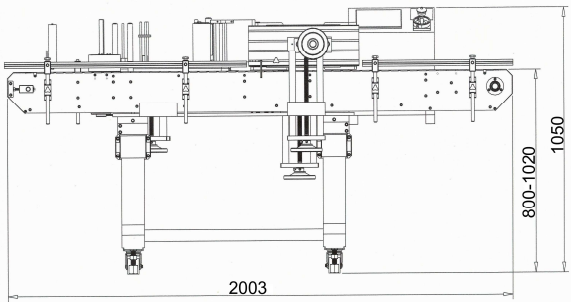

Specifications are subject to change without notice-

**Manufactured by:**

**PACK LEADER MACHINERY INC.**  
Taiwan, R.O.C.

## The PL-501 Wrap Around Labeler has powerful features to meet production needs!!!

- ◆ The touch screen control delivers fast, easy set-up.
- ◆ The built in operation manual and instructions makes training efficient.
- ◆ Easy and fast adjustment for reliable label positioning.
- ◆ Can be adapted to different application needs allowing smooth production runs and no hassles for high efficiency.
- ◆ Stepper motor drive for accuracy.
- ◆ Set label position with a touch of a button, no need to adjust the sensor.
- ◆ When the programmable counter reaches a pre-set setting, it will automatically stop for convenient production control.
- ◆ Convenient synchronized speed selections.
- ◆ Integrated missing label detection to prevent mislabeling.
- ◆ Adjustable printer dwell time for clear coding.
- ◆ 30 memory slots to store labeling parameters for future use.
- ◆ For single product conveyor lines, it can automatically start itself and label when power is restored.
- ◆ High mobility—the intricate machine is designed for mobility. It has a square tubular H shape footprint and coupled with casters and threaded leveling feet, provides a wide range of adjustments. The fast labeling speed, aesthetic outline and small footprint contributes to its versatility. Easy to integrate into a production line or in stand alone operation, it is the best machine in terms of cost and performance.

### Exclusive Distributor in Canada:

**SPEEDWAY PACKAGING MACHINERY INC.**  
P.O. Box 520  
10 Gormley Industrial Ave., Unit 1  
Gormley, Ontario  
L0H 1G0  
905-888-5344